

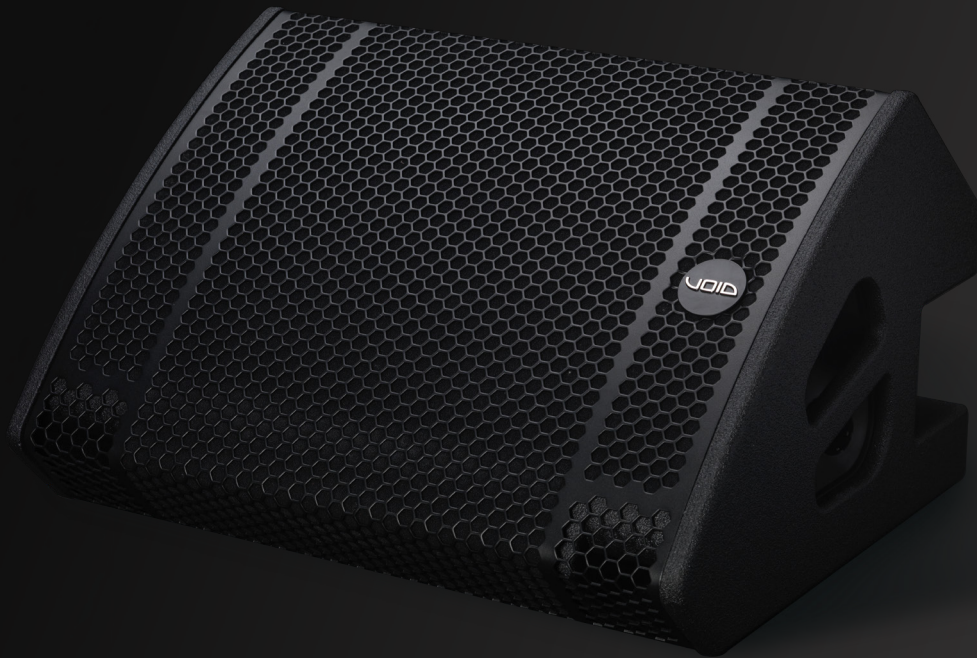

Hear. Feel. Connect.

voidacoustics.com



ArcM-12

A sound engineers dream

USER GUIDE V2.1

©2023 Void Acoustics Research Ltd.

This user guide is subject to change without notice.
For the latest online version, visit: www.voidacoustics.com

Void Acoustics and the Void logo are registered trademarks of Void Acoustics Research Ltd. in the United Kingdom, USA and other countries; all other Void trademarks are the property of Void Acoustics Research Ltd.

Contents

1	Safety and Regulations	4
1.1	Important Safety Instructions	4
1.2	Limitations	4
1.3	EC Declaration of Conformity	4
1.4	UKCA Conformity	4
1.5	Warranty Statement	4
1.6	WEEE Directive	4
2	Unpacking and Checking	5
3	About	6
3.1	Welcome	6
3.2	ArcM-12 Overview	6
3.3	Key Features	6
3.4	ArcM-12 Specifications	7
3.5	Dimensions	8
4	Cable and Wiring	9
4.1	Electrical Safety	9
4.2	Cable Considerations for Fixed Installations	9
4.3	Wiring Diagram Passive Mode	9
4.4	Bias Q2+ speakON™ wiring passive mode	10
4.5	Bias Q3/Q5 speakON™ wiring passive mode	10
4.6	Wiring Diagram Active Mode	11
4.7	Bias Q2+ speakON™ wiring active mode	11
4.8	Bias Q3/Q5 speakON™ wiring active mode	12
5	Mounting	13
5.1	Installation Safety	13
5.2	Pole Mounting	14
5.3	Ceiling Mounting	15
6	Service	18
6.1	Return Authorisation	18
6.2	Shipping and Packing consideration	18
7	Appendix	19

1 Safety and Regulations

1.1 Important safety instructions



The lightning flash with an arrowhead symbol within an equilateral triangle is intended to alert the user to the presence of uninsulated "dangerous voltage" within the product's enclosure that may be of sufficient magnitude to constitute a risk of electric shock to persons.



The exclamation point within an equilateral triangle is intended to alert the user of the presence of important operating and maintenance (servicing) instructions in the literature accompanying the appliance.

Safety instructions - read this first

1. Read these instructions.
2. Keep these instructions.
3. Heed all warnings.
4. Follow all instructions.
5. Do not use this apparatus near water.
6. Clean only with a dry cloth.
7. Do not block any ventilation openings. Install in accordance with the manufacturer's instructions.
8. Do not install near any heat source such as radiators, heat registers, stoves, or other such apparatus that produce heat.
9. Do not defeat the safety purpose of the grounding-type plug. A grounding type plug has two blades and a third grounding prong. The third prong is provided for your safety. If the provided plug does not fit into your outlet, consult an electrician for replacement of the obsolete outlet.
10. Protect power cords from being walked on or pinched particularly at plugs, convenience receptacles, and the point where they exit the apparatus.
11. Only use attachments and accessories specified by Void Acoustics.
12. Only use with the cart, stand, tripod, bracket, or table specified by the manufacturer, or sold with the apparatus. When a cart is used, use caution when moving the cart/apparatus combination to avoid injury from tip-over.
13. Unplug the apparatus during lightning storms or when unused for long periods of time.
14. Refer all servicing to qualified service personnel. Servicing is required when the apparatus has been damaged in any way, such as when the power-supply cord or plug is damaged, liquid has been spilled or objects have fallen into the apparatus, the apparatus has been exposed to rain or moisture, does not operate normally, or has been dropped.
15. Since the mains power supply cord attachment plug is used to disconnect the device, the plug should always be easily accessible.
16. Void loudspeakers can produce sound levels capable of causing permanent hearing damage from prolonged exposure. The higher the sound level, the less exposure needed to cause such damage. Avoid prolonged exposure to the high sound levels from the loudspeaker.

1.2 Limitations

This guide is provided to help familiarise the user with the loudspeaker system and its accessories. It is not intended to provide comprehensive electrical, fire, mechanical and noise training and is not a substitute for industry-approved training. Nor does this guide absolve the user of their obligation to comply with all relevant safety legislation and codes of practice. While every care has been taken in creating this guide, safety is user-dependent and Void Acoustics Research Ltd cannot guarantee complete safety whenever the system is rigged and operated.

1.3 EC declaration of conformity

For EC Declaration of Conformity please go to:

www.voidacoustics.com/eu-declaration-loudspeakers

1.4 UKCA marking

For details of the UKCA marking go to:

www.voidacoustics.com/uk-declaration-loudspeakers

1.5 Warranty statement

For warranty statement go to:

<https://voidacoustics.com/terms-conditions/>

1.6 WEEE directive

If the time arises to throw away your product, please recycle all the components possible.



This symbol indicates that when the end-user wishes to discard this product, it must be sent to separate collection facilities for recovery and recycling. By separating this product from other household-type waste, the volume of waste sent to incinerators or land-fills will be reduced and natural resources will thus be conserved.

The Waste Electrical and Electronic Equipment Directive (WEEE Directive) aims to minimise the impact of electrical and electronic goods on the environment. Void Acoustics Research Ltd complies with the Directive 2002/96/EC and 2003/108/EC of the European Parliament on waste electrical and electronic equipment (WEEE) in order to reduce the amount of WEEE that is being disposed of in land-fill sites. All of our products are marked with the WEEE symbol; this indicates that this product must NOT be disposed of with other waste. Instead it is the user's responsibility to dispose of their waste electrical and electronic equipment by handing it over to an approved reprocessor, or by returning it to Void Acoustics Research Ltd for reprocessing. For more information about where you can send your waste equipment for recycling, please contact Void Acoustics Research Ltd or one of your local distributors.

2 Unpacking and Checking

All Void Acoustics products are carefully manufactured and thoroughly tested before being despatched. Your dealer will ensure that your Void products are in pristine condition before being forwarded to you but mistakes and accidents can happen.

Before signing for your delivery:

- Inspect your shipment for any signs of contamination, abuse or transit damage as soon as you receive it
- Check your Void Acoustics delivery fully against your order
- If your shipment is incomplete or any of its contents are found to be damaged; inform the shipping company and inform your dealer.

When you are removing your ArcM 12 loudspeaker from its original packaging:

- ArcM 12 loudspeakers are boxed and stapled shut; take care when unboxing and removing the staples to avoid injury or damage to the loudspeaker
- If you need to place the ArcM 12 loudspeaker on a flat surface ensure you use a lint free product to protect the finish
- When you have removed the ArcM 12 loudspeaker from the packaging inspect it to ensure there is no damage and keep all original packaging in case it needs to be returned for any reason.

See section 1.5 for warranty conditions and see section 6 if your product needs servicing.

3 About

3.1 Welcome

Many thanks for purchasing this Void Acoustics ArcM 12 loudspeaker. We truly appreciate your support. At Void, we design, manufacture and distribute advanced professional audio systems for the installed and live sound market sectors. Like all Void products, our highly skilled and experienced engineers have successfully combined pioneering technologies with groundbreaking design aesthetics, to bring you superior sound quality and visual innovation. In buying this product, you are now part of the Void family and we hope using it brings you years of satisfaction. This guide will help you both use this product safely and ensure it performs to its full capability.

3.2 ArcM 12 overview

The ArcM 12 has multiple working angles, allowing it to be used as a near field booth monitor or conventional stage wedge, as well as having the ability to be pole mounted or wall mounted for front-of-house purposes. In terms of mobility, measures have been taken to reduce weight, while maintaining an ergonomic design to appease manual handling requirements. Acoustically, FEA analysis has significantly reduced port noise and air distortion. The 12" ArcM 12 is unpowered, allowing it to integrate with touring operators' existing infrastructure.

3.3 Key features

- High power 12" + 1.4" coaxial neodymium transducer
- Two wedge operating modes (stage and nearfield monitoring)
- Integral pole mount for 35 mm diameter poles
- Low profile design for cleaner stage lines
- Ergonomically designed handles for easy manual handling
- External dimensions optimised for truck packing
- Hard-wearing polyurea finish
- Type 80 rear mounting plate for wall or ceiling fixing

3 About

3.4 ArcM 12 specifications

Frequency response	60 Hz - 18 kHz ± 3 dB
Efficiency ¹	100 dB 1W/1m
Crossover point	1k2Hz (acoustic)
Nominal impedance	1 x 8 Ω passive, 1 x 8 Ω (LF) and 1 x 16 Ω (HF) active
Power handling ²	500 W AES
Maximum output ³	126 dB cont, 132 dB peak
Driver configuration	Coaxial 1 x 12" - 1 x 1.4" neodymium
Dispersion	80°H x 80°V
Connectors	2 x 4-pole speakON™ NL4
Height	330 mm (13")
Width	550 mm (21.7")
Depth	463 mm (18.2")
Weight	19 kg (41.9 lbs)
Rigging	Integral top hat, type 80 mounting bracket
Finish	Textured polyurethane

¹ Measured in half space ² AES2 - 1984 compliant ³ Calculated

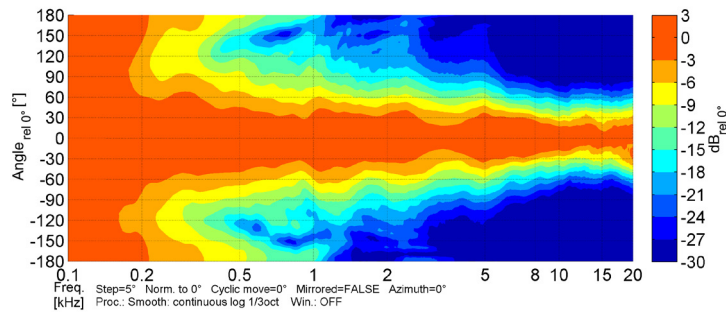

Figure 4.1: Horizontal directivity isobars

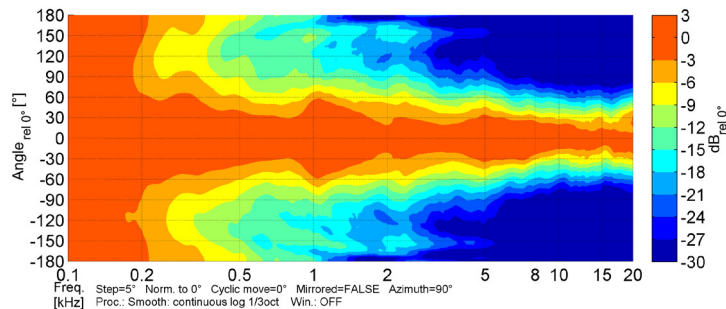

Figure 4.2: Vertical directivity isobars

3 About

3.5 Dimensions

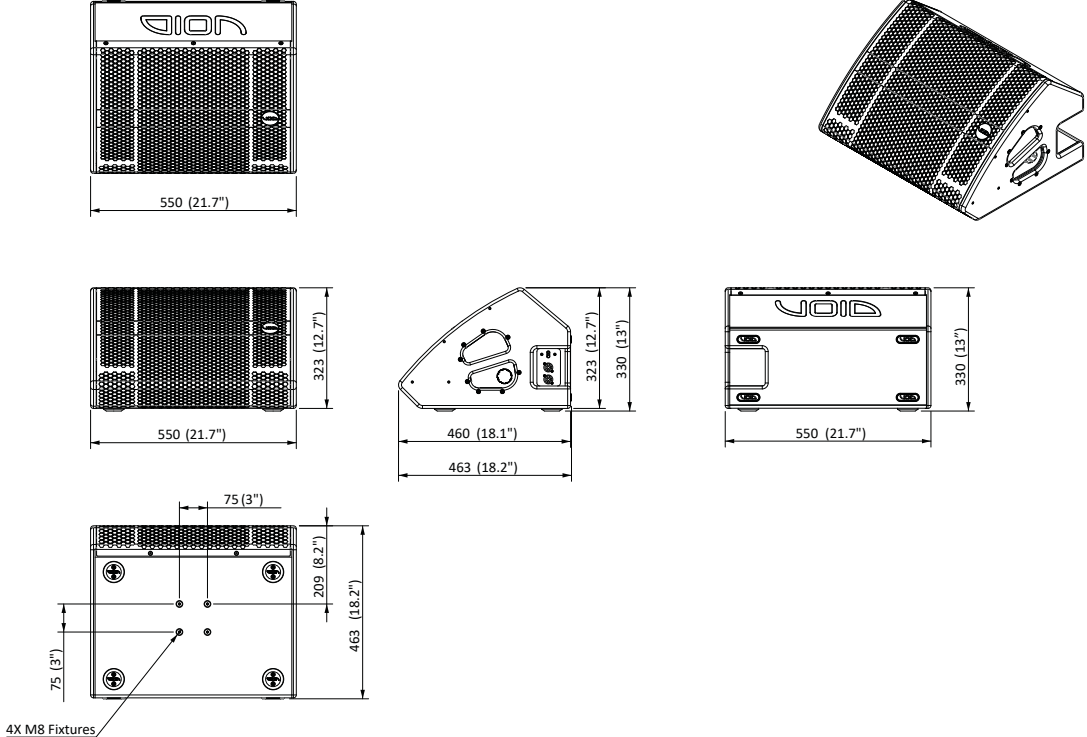

Figure 4.3: Dimensions

4 Cable and Wiring

4.1 Electrical safety

To avoid electrical hazards please note the following:



- Do not access the inside of any electrical equipment. Refer servicing to Void-approved service agents.

4.2 Cable considerations for fixed installations

We recommend specifying installation-grade Low Smoke Zero Halogen (LSZH) cables for permanent installations. The cables should use Oxygen Free Copper (OFC) of grade C11000 or above. Cables for permanent installations should be compliant with the following standards:

- IEC 60332.1 Fire retardancy of a single cable
- IEC 60332.3C Fire retardancy of bunched cables
- IEC 60754.1 Amount of Halogen Gas Emissions
- IEC 60754.2 Degree of acidity of released gases
- IEC 61034.2 Measurement of smoke density.

We suggest using the following maximum copper cable lengths to keep level losses below 0.6 dB.

Metric mm ²	Imperial AWG	16 Ω load	8 Ω load	4 Ω load	2 Ω load
2.50 mm ²	13 AWG	72 m	36 m	18 m	9 m
4.00 mm ²	11 AWG	120 m	60 m	30 m	15 m

4.3 Wiring diagram passive mode

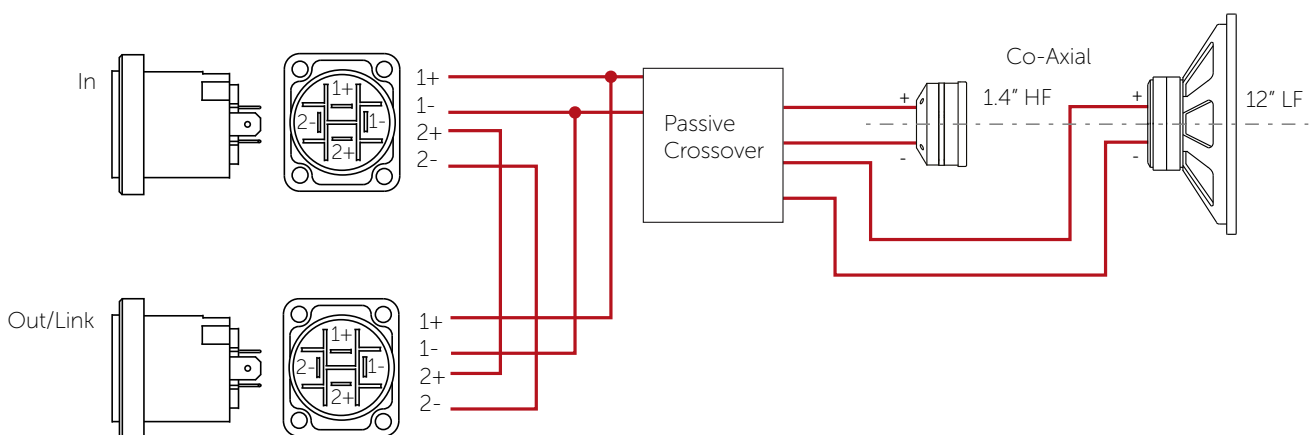

Figure 5.1: ArcM 12 passive mode wiring diagram

	speakON™ pins 1+/1-	speakON™ pins 2+/2-
In	HF (1.4") and LF (12")	Link/out
Out	Link/out	Link/out

4 Cable and Wiring

4.4 Bias Q2+ speakON™ wiring passive mode

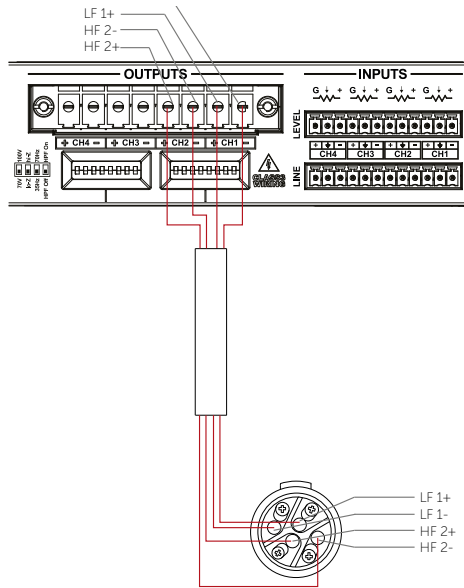

Figure 4.2: Bias Q2

Bias Q2+	Output 1 or 2
Output	LF (12") and HF (1.4")
Max parallel units	4 (2 Ω load to amplifier)

4.5 Bias Q3/Q5 speakON™ wiring passive mode

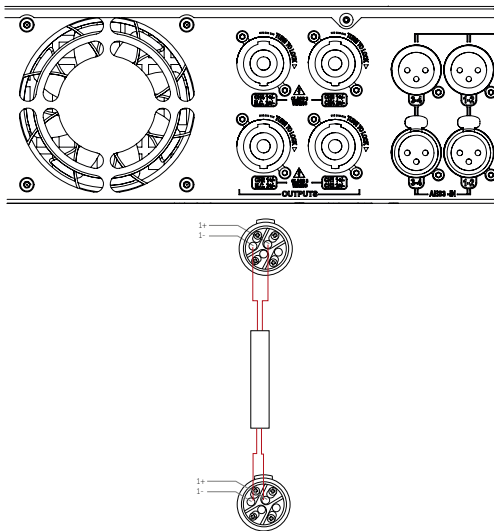

Figure 4.3: Bias Q3

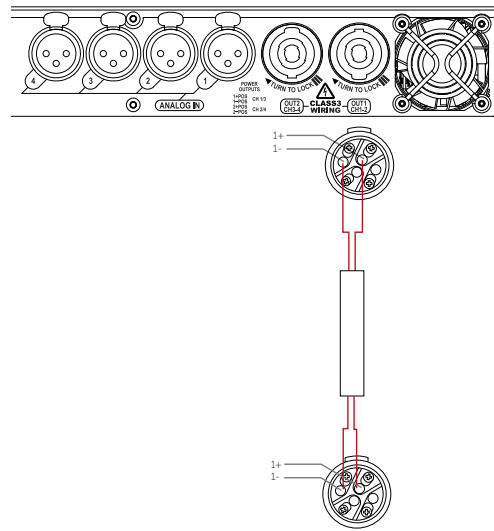

Figure 4.4: Bias Q5

Bias Q3/Q5	Single channel
Output	LF (12") and HF (1.4")
Max parallel units	4 (2 Ω load to amplifier)

4 Cable and Wiring

4.6 Wiring diagram active mode

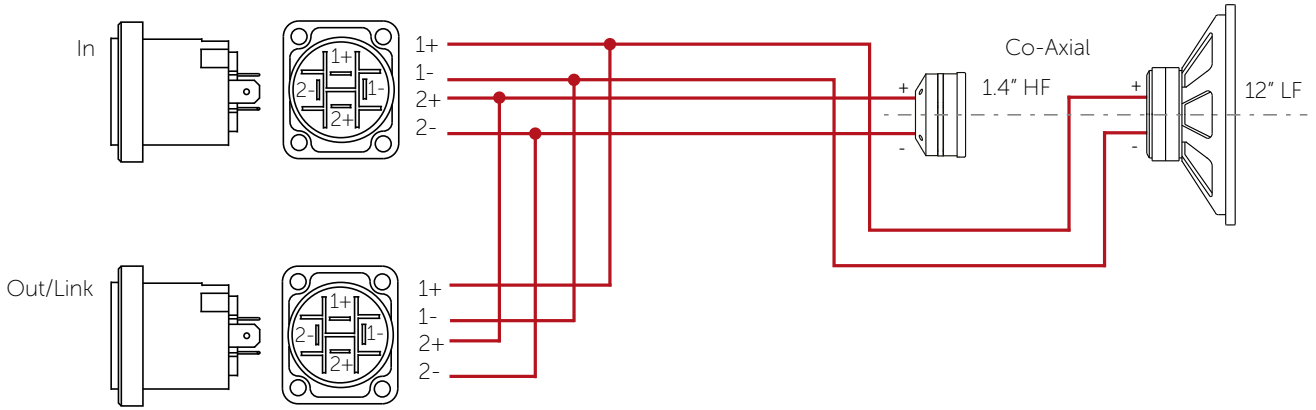

Figure 4.5: ArcM 12 active mode wiring diagram

	speakON™ pins 1+/1-	speakON™ pins 2+/2-
In	LF (12")	HF (1.4")
Out	Link/out	Link/out

4.7 Bias Q2+ speakON™ wiring active mode

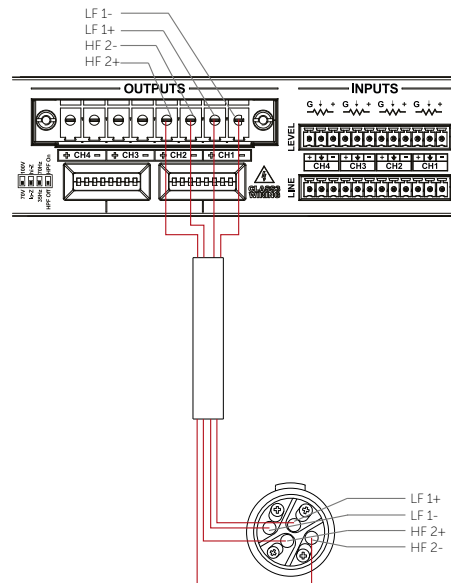

Figure 4.6: Bias Q2

Bias Q2+	Output 1	Output 2
Output	LF (12")	HF (1.4")
Max parallel units	4 (2 Ω load to amplifier)	4 (4 Ω load to amplifier)

4 Cable and Wiring

4.8 Bias Q3/Q5 speakON™ wiring active mode

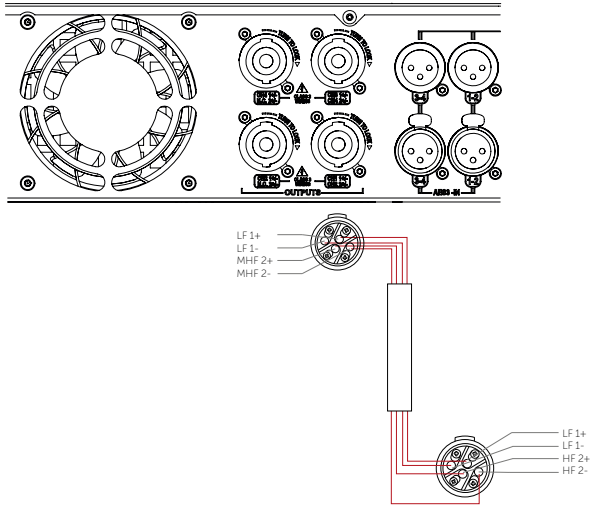

Figure 4.7: Bias Q5

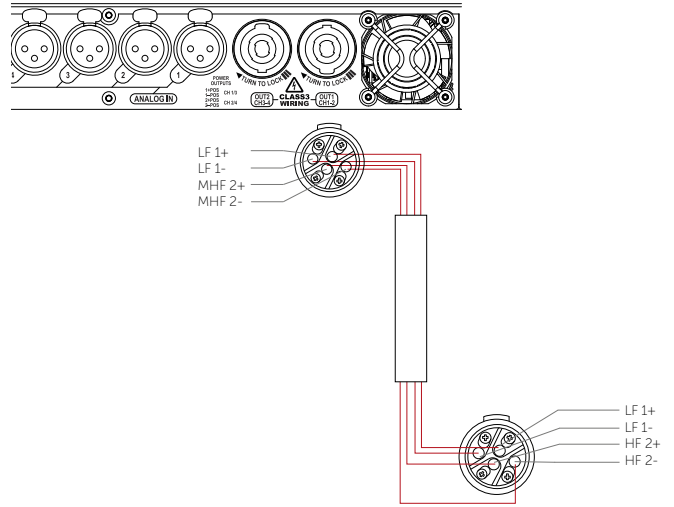

Figure 4.8: Bias Q5

Bias Q3/Q5	Output 1	Output 2
Output	LF (12")	HF (1.4")
Max parallel units	4 (2 Ω load to amplifier)	4 (4 Ω load to amplifier)

5 Mounting

Tools required

- 19 mm ratchet spanner/wrench
- 6 mm Allen key

5.1 Installation safety



To avoid mechanical hazards, please note the following:

- Safety regulations vary in different regions. Full compliance with those regulations must be your priority
- Installations must only be undertaken by fully qualified and experienced engineers/technicians who understand local regulations
- This may include consulting a structural engineer before installation of wall brackets
- Remember that all personnel have a duty of care to themselves, to their assistants, to the venue staff and to the public
- Before lifting any part of the system above head height, check the whole rig for loose tools or other items that may fall and cause injury
- Do not use a telephone (even if hands-free) whilst installing. Always concentrate fully on the installation operation
- Do not install equipment that is worn, damaged, corroded, mishandled or overstressed in any way
- Use only Void-approved mounting equipment and accessories
- Secondary safeties should be provided in all instances where cabinets are flying or fixing overhead and should conform to local regulations

5.2 Pole Mounting

Parts required:

- 35 mm pole



Figure 5.1: 35 mm pole

Step 1:

Once the pole has been fitted to an appropriate mount raise the ArcM 12 loudspeaker into position.

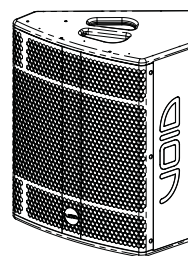

Figure 5.2: Loudspeaker positioning

Step 2:

Lower the ArcM 12 loudspeaker on the pole using the integrated top hat within the cup handle. Rotate to the desired horizontal angle.

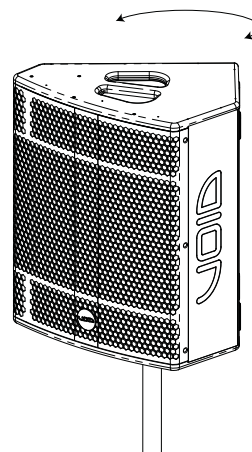

Figure 5.3: Loudspeaker positioning

5.3 Ceiling Mounting

Parts required:

T80 - Ceiling Bracket (350mm)	White - IT1106
	Black - IT1105

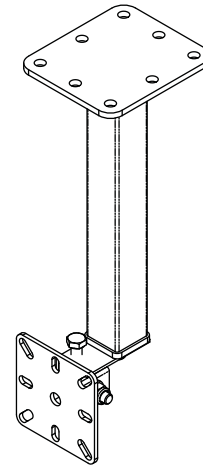

Figure 5.4: Ceiling bracket

Step 1:

Remove all four M8 countersink bolts from the base of the ArcM 12.

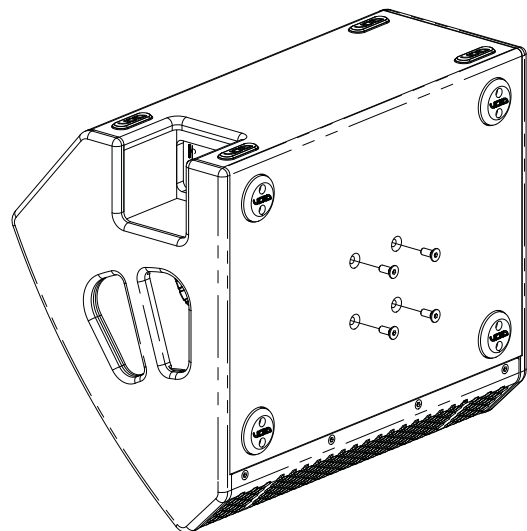

Figure 5.5: Bolt removal

Step 2:

Remove the mount plate from the T80 bracket by removing the M10 nut as shown.

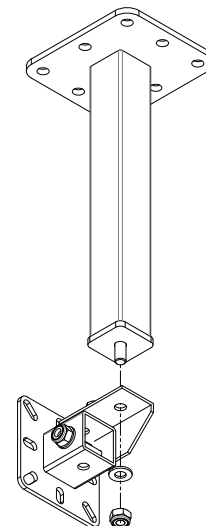

Figure 5.6: Fixing bracket

5.3 Ceiling Mounting

Step 3:

Attach the mounting bracket to the base of the cabinet using all four bolts, spring washers and washers provided with the bracket.

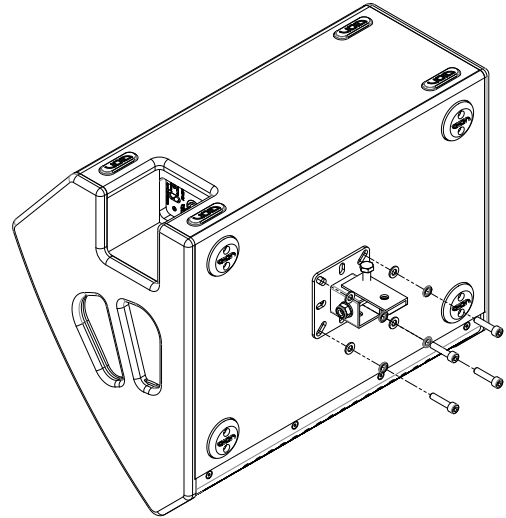

Figure 5.7: Mounting plate attachment

Step 4:

Attach the mounting plate to the ceiling bracket

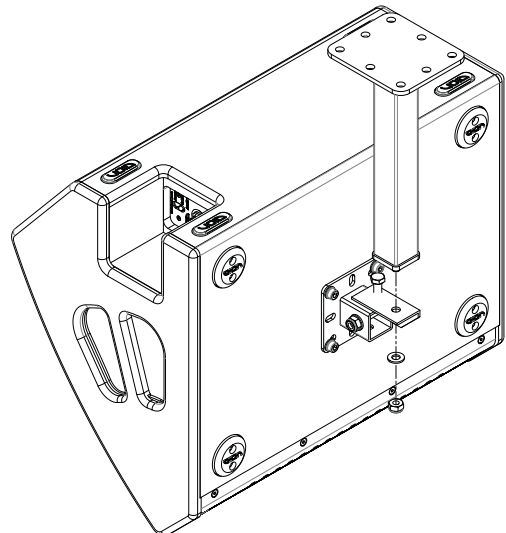

Figure 5.8: Ceiling bracket attachment

Step 5:

With the lifting gear in place adjust the angle of the bracket using the bolt on the bracket assembly.

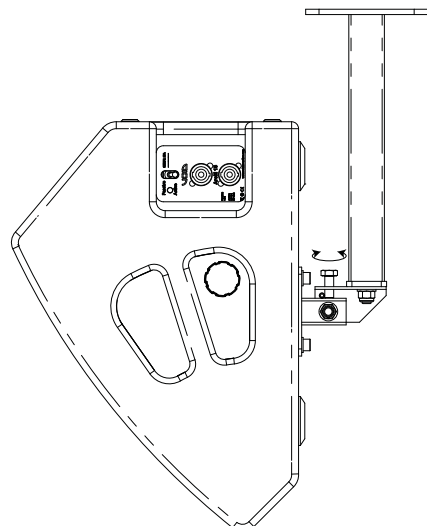

Figure 5.9: Adjust angle

5.3 Ceiling Mounting

Step 6:

Tighten the bolt on the bracket to fix the loudspeaker in position.

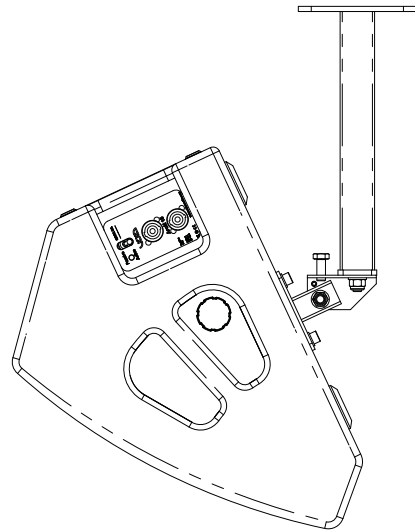

Figure 5.10: Loudspeaker positioning

Note:

It is possible to mount the ArcM loudspeaker 180° as shown in figure 7.9. Follow the procedure detailed above.

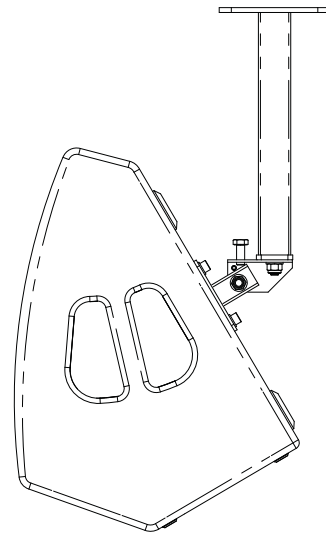

Figure 5.11: Alternative mounting orientation

6 Service

Void ArcM 12 loudspeakers should only be serviced by a fully-trained technician.



No user serviceable parts inside. Refer servicing to your dealer.

6.1 Return authorisation

Before returning your faulty product for repair, please remember to get an R.A.N. (Return Authorisation Number) from the Void dealer who supplied the system to you. Your dealer will handle the necessary paperwork and repair. Failure to go through this return authorisation procedure could delay the repair of your product.

Note that your dealer will need to see a copy of your sales receipt as proof of purchase so please have this to hand when applying for return authorisation.

6.2 Shipping and packing considerations

- When sending a Void ArcM 12 loudspeaker to an authorised service centre, please write a detailed description of the fault and list any other equipment used in conjunction with the faulty product.
- Accessories will not be required. Do not send the instruction manual, cables or any other hardware unless your dealer asks you to.
- Pack your unit in the original factory packaging if possible. Include a note of the fault description with the product. Do not send it separately.
- Ensure safe transportation of your unit to the authorised service centre.

7 Appendix

Architectural specification

The loudspeaker shall be a passive, two-way, bi-amped system consisting of one high power 12" (304.8 mm) direct radiating reflex loaded low frequency (LF) transducer and 1.4" (35.56 mm) exit diameter (HF) co-axially-mounted neodymium high frequency (HF) compression transducer in a 15 mm birch ply enclosure.

The low frequency transducer shall be constructed on a cast aluminium frame, with a treated paper cone, 88 mm (3.5") voice coil, wound with aluminium wires on a high quality voice coil former, for high power handling and long term-reliability. The high frequency transducer shall be bolted through the rear of the magnet structure belonging to the LF transducer to form a co-axial drive unit. The sound will project through a machined waveguide that exits in the centre of the low frequency transducer to use the 203.2 mm (8") baffle diameter to achieve pattern control and low distortion.

Performance specifications for a typical production unit shall be as follows: the usable on-axis bandwidth shall be 60 Hz to 18 kHz (± 3 dB) and shall average 80° directivity pattern for both horizontal and vertical axis (-6 dB down from on-axis level) from 1 kHz to 12 kHz; maximum SPL of 126 dB continuous, 132 dB peak measured at 1 m using IEC268-5 pink noise. Power handling shall be 500 W AES at a rated impedance of 8 Ω ; crossover point at 1.2 kHz using a 2nd order filter (12 dB per octave). The system shall be powered by its own dedicated power amplification module with DSP management.

The enclosure shall be of a trapezoidal asymmetrical shape constructed from a 15 mm 13-laminate birch plywood with a textured polyurea finish and shall contain fixture points for a pressed, weather-resistant, powder-coated steel grille with foam filter to protect the transducers. The cabinet shall have an integral pole mount socket and a type 80 mounting point to suit portable and permanent applications. External dimensions of (W) 550 mm x (H) 330 mm x (D) 463 mm (21.7" x 13" x 18.2"). Weight shall be 19 kg (41.9 lbs).

The loudspeaker shall be the Void Acoustics ArcM 12.

NORTH AMERICA

Void Acoustics North America

Call: +1 630 686 6616

Email: hello@voidacoustics.com

HEAD OFFICE

Void Acoustics Research Ltd,
Unit 15, Dawkins Road Industrial Estate,
Poole, Dorset,
BH15 4JY
United Kingdom

Call: +44(0) 1202 666006

Email: hello@voidacoustics.com



Hear. Feel. Connect.

voidacoustics.com